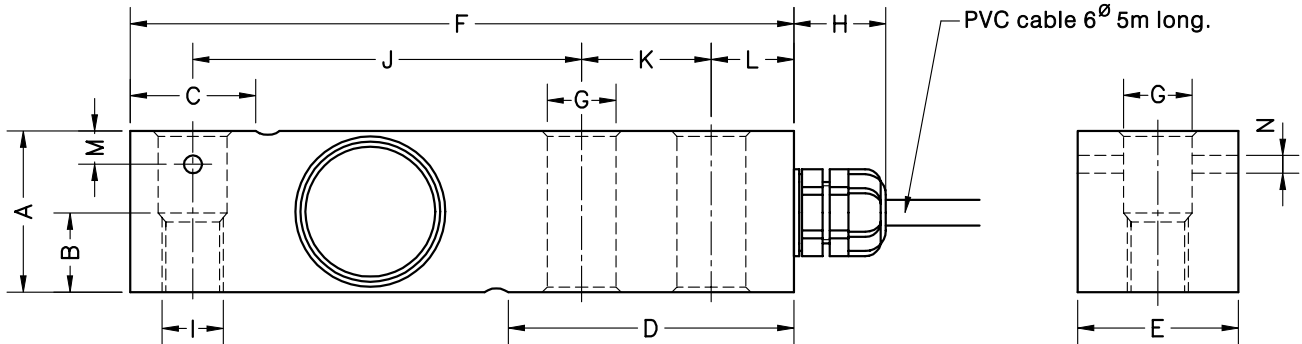

- Célula de carga de cizallamiento
- Versiones:
  - **350i** (300...5000kg): Totalmente en acero inox. Sellado hermético, completamente soldada, IP 68 (EN 60529) e IP 69K (ISO 20653)
  - **350a** (300...5000kg): Construcción en acero inox. Sellado silicona, IP 66 (EN 60529)
  - **350n** (300...2000kg): Construcción en acero niquelado. Sellado silicona, IP 66 (EN 60529)
- 3000 divisiones OIML R60 clase C
- Preajuste de esquinas optimizado para sistemas multicélulas
- Disponible en versión **ATEX** (opcional) Zona 0-1-2 (gas) y 20-21-22 (polvo)
- Aplicaciones industriales de alta precisión:
  - plataformas con 4 células
  - reactores, tanques y tolvas

- Shear beam load cell
- Versions:
  - **350i** (300...5000kg): Fully Stainless Steel construction. Hermetically sealed, fully welded, IP 68 (EN 60529) and IP 69K (ISO 20653)
  - **350a** (300...5000kg): Stainless Steel construction. Silicone sealing, IP 66 (EN 60529)
  - **350n** (300...2000kg): Nickel-plated Alloy Steel. Silicone sealing, IP 66 (EN 60529)
- 3000 divisions OIML R60 class C
- Pre-corner adjustment optimized for multicell systems
- Available in **ATEX** version (optional) Zone 0-1-2 (gas) and 20-21-22 (dust)
- High accuracy on industrial applications:
  - four load cells platforms
  - tanks and hoppers weighing

Modelo Model	Carga nominal Nominal capacity Ln	Clase de precisión Accuracy class n. OIML	División mínima Minimum division vmin	Carga de servicio Service load 150 % Ln	Carga límite Safe load 200 % Ln
350 300 kg	300 kg	3000	30 g	450 kg	600 kg
350 500 kg	500 kg	3000	50 g	750 kg	1000 kg
350 750 kg	750 kg	3000	75 g	1125 kg	1500 kg
350 1000 kg	1000 kg	3000	100 g	1500 kg	2000 kg
350 1500 kg	1500 kg	3000	150 g	2250 kg	3000 kg
350 2000 kg	2000 kg	3000	200 g	3000 kg	4000 kg
350 3000 kg	3000 kg	3000	300 g	4500 kg	6000 kg
350 5000 kg	5000 kg	3000	500 g	7500 kg	10000 kg

**Mod. 350i/a (300...5000kg)**
**Mod. 350n (300...2000kg)**

Carga nominal Nominal load	A	B	C	D	E	F	G <sup>Ø</sup>	H	I	J	K	L	M	N <sup>Ø</sup>	Peso transporte Transport weight
300-500-750-1000-1500-2000 kg	31.5	15	24.6	56	31.5	130	13.5	18	M12	76.2	25.4	15.8	6.5	3.5	0.9 kg
3000-5000 kg	48	-	37	76	41.5	171.5	20.5	18	-	95.2	38.1	19	-	-	2.2 kg

 Dimensiones en mm. *Dimensions in mm.*

ESPECIFICACIONES			SPECIFICATIONS
Cargas nominales (Ln)	300-500-750-1000-1500-2000-3000-5000	kg	Nominal capacities (Ln)
Clase de precisión	3000	n. OIML	Accuracy class
Carga mínima	0	%Ln	Minimum dead load
Carga de servicio	150	%Ln	Service load
Cargas límite	200	%Ln	Safe load limit
Error combinado	< ±0.017	%Sn (1)	Total error
Error repetibilidad	< ±0.015	%Sn	Repeatability error
Efecto de la temperatura: en el cero	< ±0.01	%Sn/5 °C	Temperature effect: on zero
en la sensibilidad	< ±0.006	%Sn/5 °C	on sensitivity
Error de fluencia (30 minutos)	< ±0.016	%Sn	Creep error (30 minutes)
Compensación de temperatura	-10...+40	°C	Temperature compensation
Límites de temperatura	-30...+70	°C	Temperature limits
Sensibilidad nominal (Sn)	2	mV/V (2)	Nominal sensitivity (Sn)
Tensión de alimentación nominal	10	V	Nominal input voltage
Tensión de alimentación máxima	15	V	Maximum input voltage
Resistencia de entrada	400 ±20	Ω	Input impedance
Resistencia de salida	350 ±3	Ω	Output impedance
Desequilibrio inicial	< ±2	%Sn	No load output
Resistencia de aislamiento	> 5000	MΩ	Insulation resistance
Deformación máxima (a Ln)	0.2-0.4	mm	Maximum deflection (at Ln)

 CONEXIÓN ELÉCTRICA  
ELECTRICAL CONNECTION:

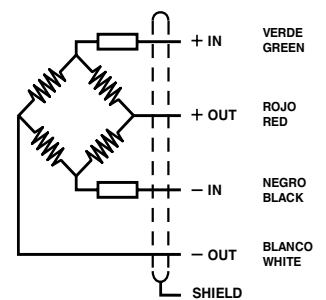
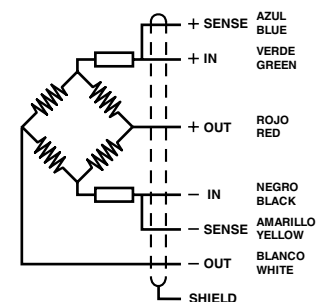
**MOD. 350a/350n**

**MOD. 350i**

(1) Error combinado: No Linealidad e Histéresis / Total error: Non Linearity and Hysteresis

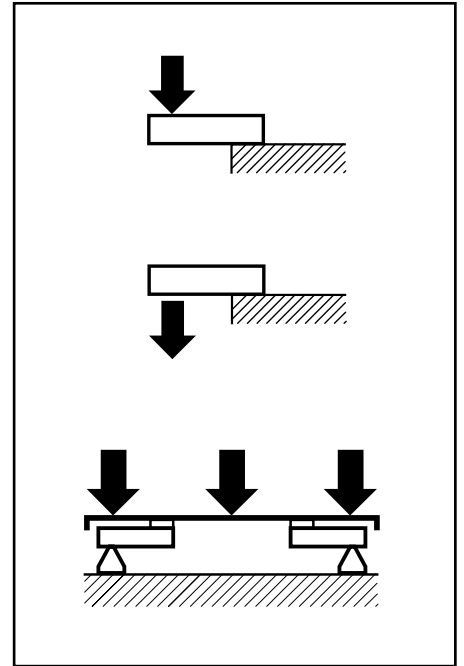
 (2) Preajuste de esquinas optimizado al ±0.05% mediante la calibración de la corriente de salida /  
Pre-corner adjustment optimized at ±0.05% by output current calibration



- Célula de carga de cizallamiento
- Totalmente en acero inoxidable
- Sellado hermético, completamente soldada
- Protección IP 68 (EN 60529) e IP 69K (ISO 20653)
- 3000 divisiones OIML R60 clase C
- Preajuste de esquinas optimizado para sistemas multicélulas
- Aplicaciones industriales de alta precisión:
  - plataformas con 4 células
  - reactores, tanques y tolvas
  - básculas puente para vehículos ligeros
  - pesaejes
  - pesaje "on-board"
- Shear beam load cell
- Fully Stainless Steel construction
- Hermetically sealed, fully welded
- Protected IP 68 (EN 60529) and IP 69K (ISO 20653)
- 3000 divisions OIML R60 class C
- Pre-corner adjustment optimized for multicell systems
- High accuracy on industrial applications:
  - four load cells platforms
  - tanks and hoppers weighing
  - light vehicle weighbridges
  - axle weighing
  - "on-board" weighing

Modelo Model	Carga nominal Nominal capacity Ln	Clase de precisión Accuracy class n. OIML	División mínima Minimum division vmin	Carga de servicio Service load 150 % Ln	Carga límite Safe load 200 % Ln
350 7500 kg	7500 kg	3000	0.75 kg	11250 kg	15000 kg
350 10000 kg	10000 kg	3000	1 kg	15000 kg	20000 kg

# MODELO 350 (7500...10000kg)

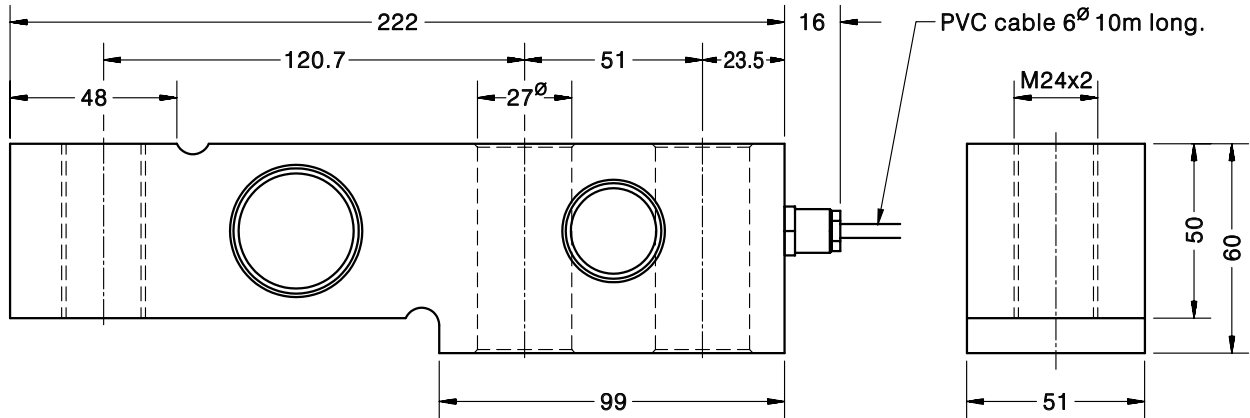

Dimensiones en mm. *Dimensions in mm.*

Peso transporte - *Transport weight:* 4.3 kg

ESPECIFICACIONES			SPECIFICATIONS
Cargas nominales (Ln)	7500-10000	kg	Nominal capacities (Ln)
Clase de precisión	3000	n. OIML	Accuracy class
Carga mínima	0	%Ln	Minimum dead load
Carga de servicio	150	%Ln	Service load
Cargas límite	200	%Ln	Safe load limit
Error combinado	< ±0.017	%Sn (1)	Total error
Error repetibilidad	< ±0.015	%Sn	Repeatability error
Efecto de la temperatura: en el cero	< ±0.01	%Sn/5 °C	Temperature effect: on zero
en la sensibilidad	< ±0.006	%Sn/5 °C	on sensitivity
Error de fluencia (30 minutos)	< ±0.016	%Sn	Creep error (30 minutes)
Compensación de temperatura	-10...+40	°C	Temperature compensation
Límites de temperatura	-30...+70	°C	Temperature limits
Sensibilidad nominal (Sn)	2	mV/V (2)	Nominal sensitivity (Sn)
Tensión de alimentación nominal	10	V	Nominal input voltage
Tensión de alimentación máxima	15	V	Maximum input voltage
Resistencia de entrada	400 ±20	Ω	Input impedance
Resistencia de salida	350 ±3	Ω	Output impedance
Desequilibrio inicial	< ±2	%Sn	No load output
Resistencia de aislamiento	> 5000	MΩ	Insulation resistance
Deformación máxima (a Ln)	0.2-0.4	mm	Maximum deflection (at Ln)

## CONEXIÓN ELÉCTRICA ELECTRICAL CONNECTION:

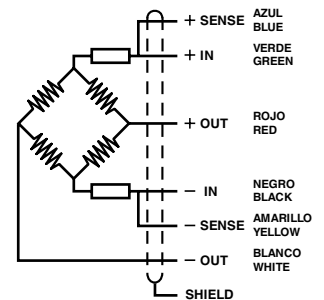

«SENSES»: 2 hilos adicionales, para mantener constante la alimentación en la célula, con una instrumentación adecuada. Utilizar especialmente para cables largos y amplio margen de temperatura.  
PANTALLA: No conectada al cuerpo del transductor.

«SENSES»: 2 additional wires to maintain a constant voltage supply at the load cell when used with proper instrumentation. Use specially when long wires and wide temperature range.  
SHIELD: Not connected to transducer body.

(1) Error combinado: No Linealidad e Histéresis / Total error: Non Linearity and Hysteresis

(2) Preajuste de esquinas optimizado al ±0.05% mediante la calibración de la corriente de salida / Pre-corner adjustment optimized at ±0.05% by output current calibration

**ACCESORIO PIE AUTOCENTRANTE PARA MOD. 340-350**  
**LOAD FOOT ACCESSORY FOR MODELS 340-350**

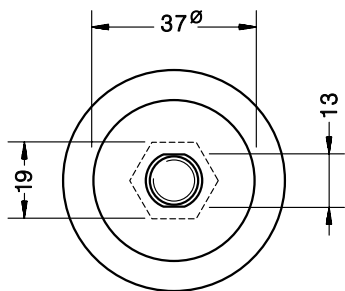
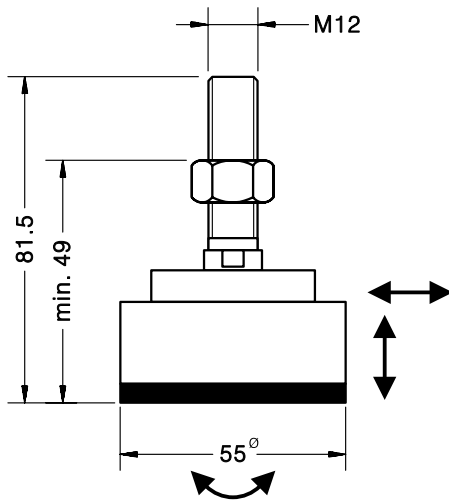

- **Materiales: acero inoxidable y goma natural**
- **Materials: Stainless Steel and Rubber**

**Acc. 35901 para Mod. 350 (300...2000 kg) / For Mod. 350 (300...2000 kg)**

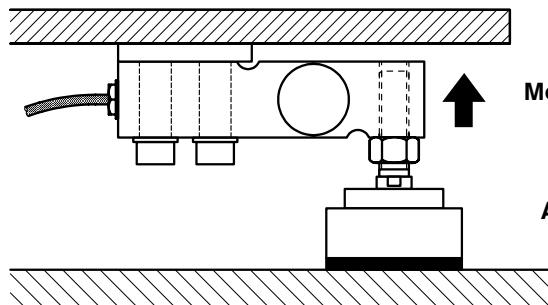
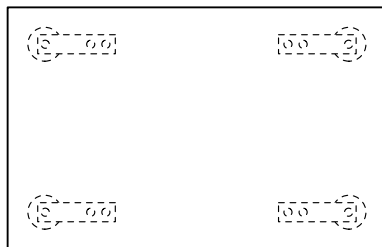

**Mod. 340-350**  
+  
**Acc. 35901**

Dimensiones en mm. *Dimensions in mm.*

Peso transporte - *Transport weight:* 0.33 kg

**ACCESORIO PIE AUTOCENTRANTE PARA MOD. 340-350  
LOAD FOOT ACCESSORY FOR MODELS 340-350**

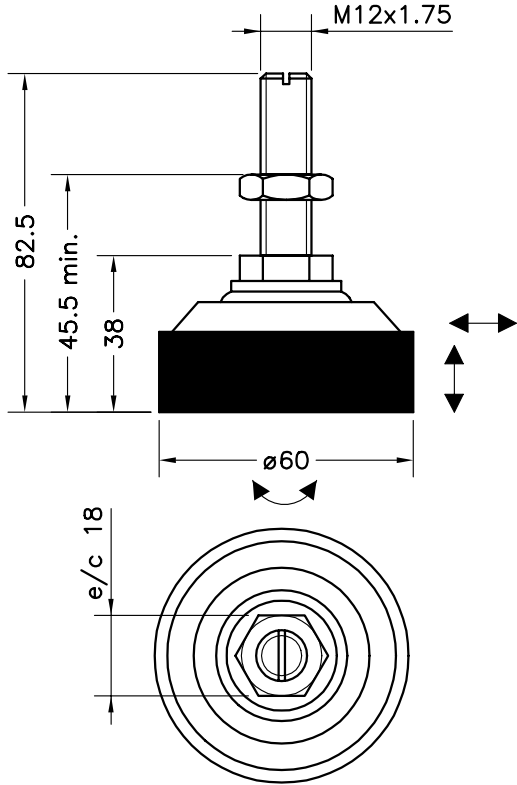

- **Materiales: acero inoxidable y goma natural**
- **Materials: Stainless Steel and Rubber**

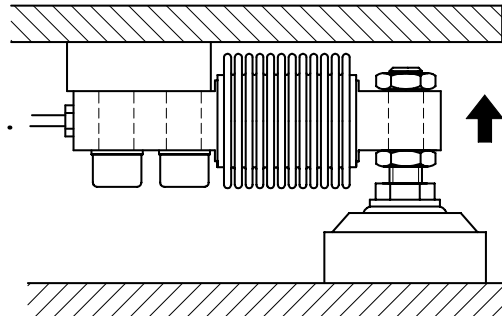
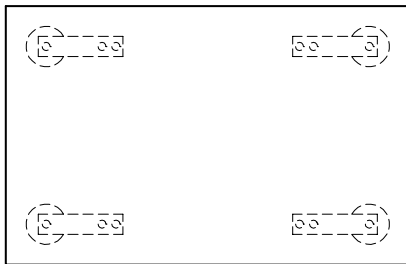
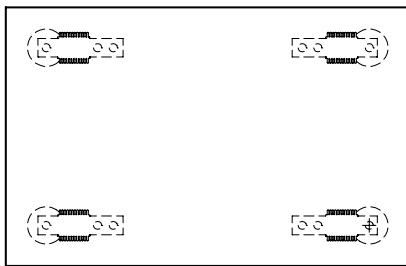

**Mod. 340**  
+  
**Acc. FT12i**

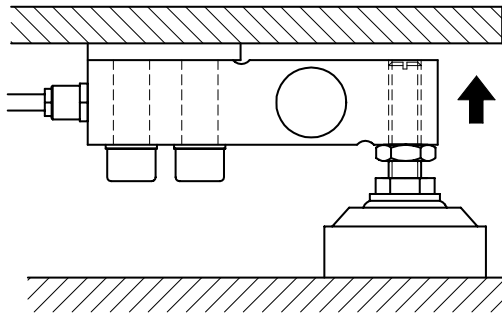

**Mod. 350**  
**(300...2000 kg)**  
+  
**Acc. FT12i**

Dimensiones en mm. *Dimensions in mm.*

Peso transporte - *Transport weight:* 0.42 kg

# SOPORTE TANQUES CON ANTIVUELCO PARA MOD. 350

## MOUNTING-KIT LIFT-OFF PREVENTION FOR MOD. 350

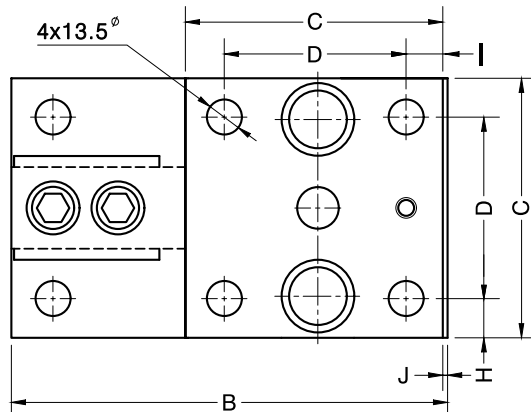
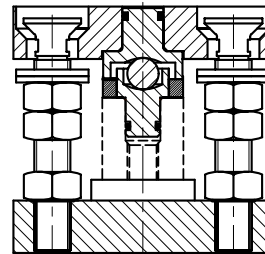
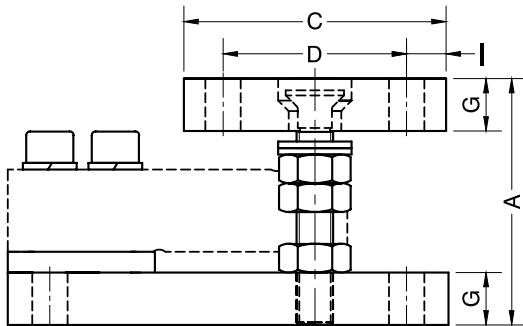
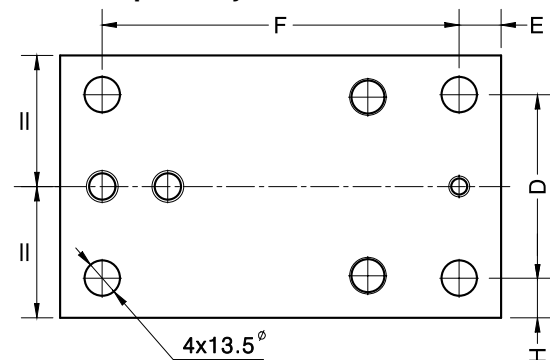
**Material:**
**Acero cincado**                      **Acc. 35902-35903**
**Acero inoxidable**                    **Acc. 35902i-35903i**
**Material:**
**Alloy Steel zinc-plated**   **Acc. 35902-35903**
**Stainless Steel**                      **Acc. 35902i-35903i**

**Vista por abajo / View from below**

Accesorio Accessory	Carga nominal Nominal load	A	B	C	D	E	F	G	H	I	J	Peso transporte Transport weight
<b>35902</b>	0.3...2 t	94	168	100	70	16	136	20	15	15	1	5 kg
<b>35903</b>	3...5 t	113	212	120	84	18	175	25	18	18	-	8.5 kg

	Acero cincado / Alloy Steel zinc-plated		Acero inoxidable / Stainless Steel	
	<b>35902</b>	<b>35903</b>	<b>35902i</b>	<b>35903i</b>
Máximo desplazamiento transversal a célula <i>Maximum permissible offset transverse to load cell</i>	±2.5 mm	±2 mm	±2.5 mm	±2 mm
Máxima fuerza de levantamiento <i>Maximum lift-off force</i>	69 kN	113.04 kN	69 kN	113.04 kN
Máxima fuerza horizontal a la célula de carga <i>Maximum force horizontal to load cell</i>	7.93 kN	11.8 kN	5 kN	11.8 kN

 Dimensiones en mm. *Dimensions in mm.*

**ACCESORIO TRACCION PARA MODELO 350**  
**TENSION ACCESSORY FOR MODEL 350**

**Acc. 35907 (0.3...2t)**

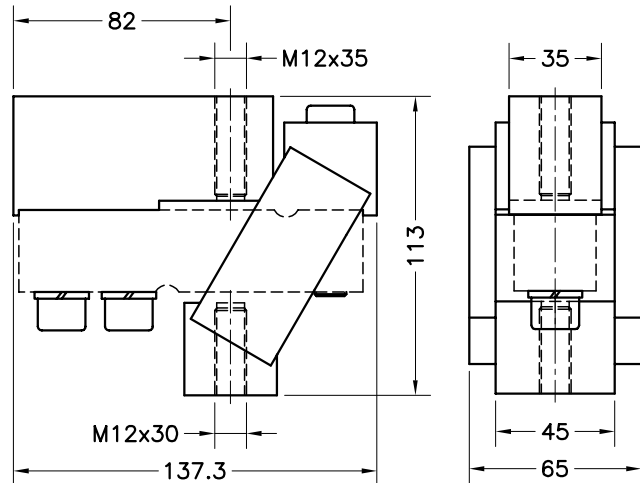

- **Material: Acero cincado / Material: Alloy Steel zinc-plated**
- **Carga límite: 4000 kg / Ultimate load: 4000 kg**

Dimensiones en mm. *Dimensions in mm.*

Peso transporte - *Transport weight: 2.5 kg*

**Acc. 35908 (3...5t)**

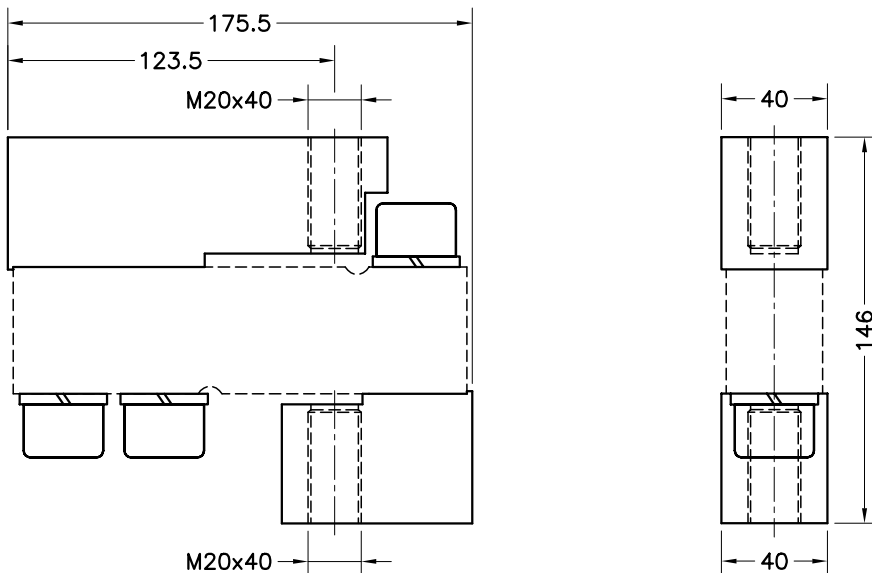

- **Material: Acero cincado / Material: Alloy Steel zinc-plated**
- **Carga límite: 10000 kg / Ultimate load: 10000 kg**

Dimensiones en mm. *Dimensions in mm.*

Peso transporte - *Transport weight: 3.8 kg*



## KIT TANQUES SILENT-BLOCK ANTIVUELCO PARA MOD. 350

## TANK KIT SILENT-BLOCK LIFT-OFF PREVENTION FOR MOD. 350

- **Material: Acero cincado - goma Acc. 359xx**  
**Acero inox. - goma Acc. 359xxi**
  
- **Material: Alloy Steel zinc-plated - Rubber**  
**Acc. 359xx**  
**Stainless Steel - Rubber**  
**Acc. 359xxi**

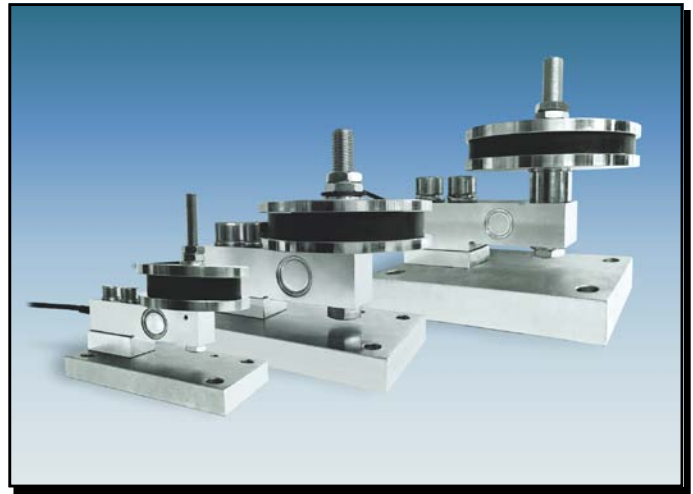

### Acc. 35909-35910-35918: Con silent-block antivuelco / Silent-block with lift-off prevention

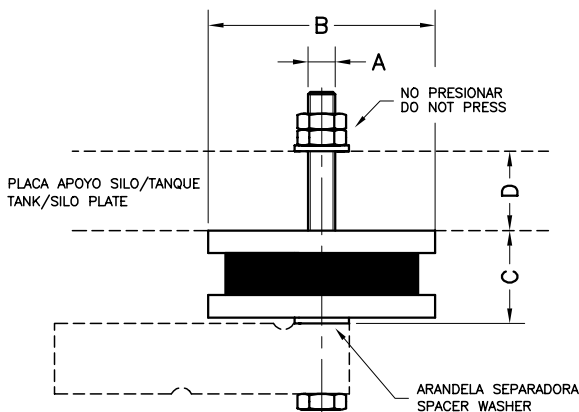

Accesorio Accessory	Carga Nominal Load	A	B Ø	C	D	Peso Transport Weight
<b>35909</b>	0.3...2 t	M12	100	41	0...35	2 kg
<b>35910</b>	3...5 t	M20	150	44	10...35	3.2 kg
<b>35918</b>	7.5...10 t	M24	200	84	0...50	7.8 kg

### Acc. 35911-35912-35919: Placa base / Base plate

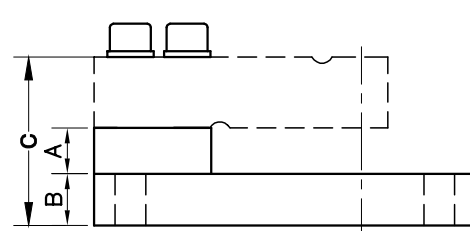
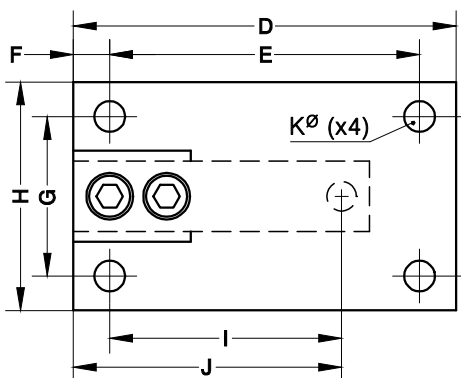

Accesorio Accessory	Carga Nominal Load	A	B	C	D	E	F	G	H	I	J	K Ø	Peso Transport Weight
<b>35911</b>	0.3...2 t	20	20	71.5	168	136	16	70	100	101.6	117.6	13.5	3.2 kg
<b>35912</b>	3...5 t	20	25	93	212	175	19	84	120	133.3	152.3	13.5	5.8 kg
<b>35919</b>	7.5...10 t	20	40	120	285	235	25.5	127	180	171.7	197.2	21	17.5 kg

Dimensiones en mm. *Dimensions in mm.*

**ACCESORIO PIE AUTOCENTRANTE PARA MOD. 350**  
**LOAD FOOT ACCESSORY FOR MODELS 350**

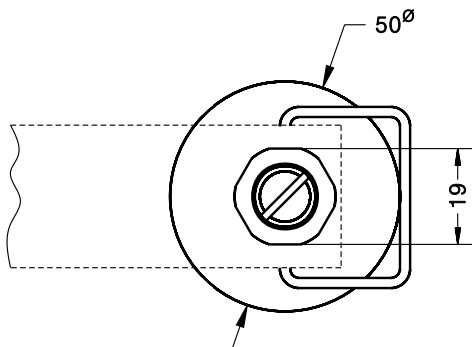
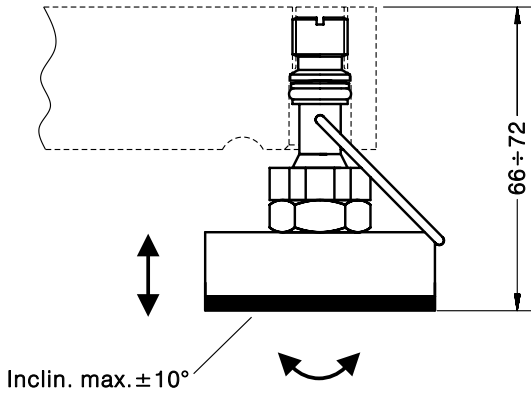

■ **Materiales:** Acero cincado y goma natural  
**Acc. 35913**

Acero inox. y goma natural  
**Acc. 35913i**

■ **Materials:** Alloy Steel zinc-plated and Rubber  
**Acc. 35913**

Stainless Steel and Rubber  
**Acc. 35913i**

**Acc. 35913 para Mod. 350 (300...2000 kg) / For Mod. 350 (300...2000 kg)**

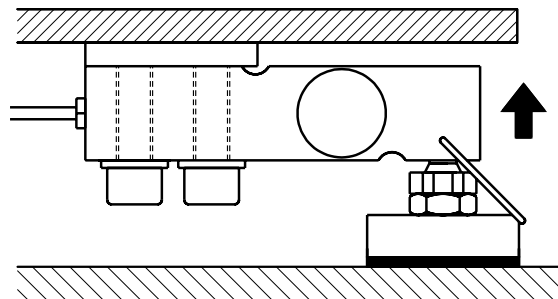
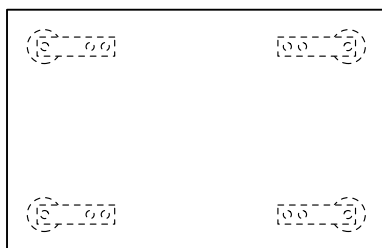

**Mod. 350**

+

**Acc. 35913**

Dimensiones en mm. *Dimensions in mm.*

Peso transporte - *Transport weight:* 0.29 kg

**ACCESORIO PIE AUTOCENTRANTE PARA MOD. 350**  
**LOAD FOOT ACCESSORY FOR MODEL 350**

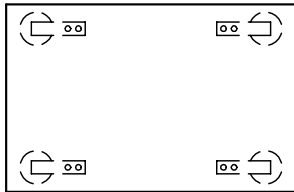

**Mod. 350**

+

**Acc. 35917i**

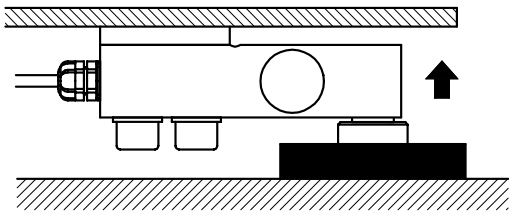

- **Materiales: acero inoxidable y goma**
- **Materials: Stainless Steel and Rubber**

**Acc. 35917i para Mod. 350 (3 - 5 t) / For Model 350 (3 - 5 t)**

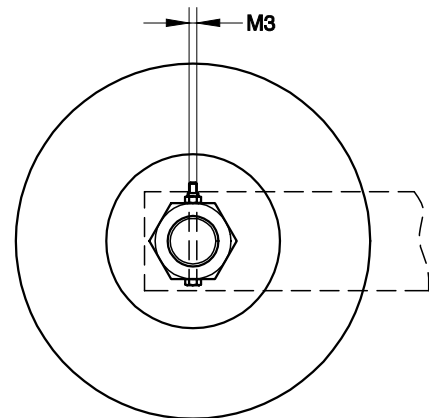
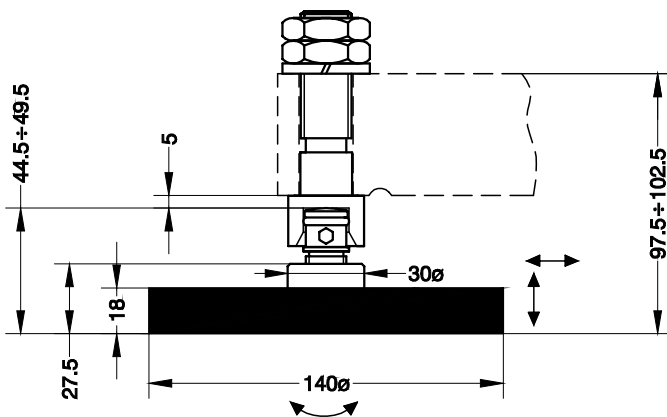

Dimensiones en mm. *Dimensions in mm.*

Peso transporte - *Transport weight:* 1.3 kg